



# ASSEMBLY INSTRUCTIONS

## Standard Corner Kits (All Models)

Questions?  
Toll free 1-888-373-6057 or visit [WineRacksAmerica.com](http://WineRacksAmerica.com)



Thank you and CONGRATULATIONS for purchasing this quality product. Properly assembled, your racking will beautifully enhance your wine collection for many years to come. To assemble, please check to ensure all necessary parts are included and follow the assembly instructions closely. If you have any questions or problems please call customer service toll free 1-888-373-6057 Monday through Friday 7:00 am - 5:00pm MST.



### Planning to stain?

For best results we recommend you stain or finish your racking BEFORE assembly.

### Tools For Assembly:

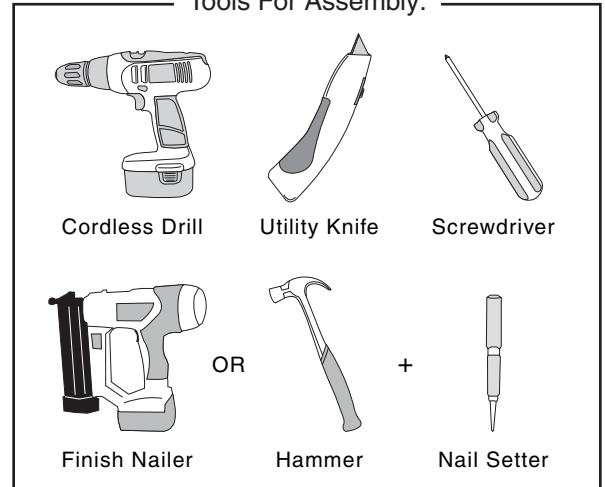

The instructions pictured are for a 5 column corner rack. Follow the same steps for the 3-column corner, and simply skip steps 13-19.

## PARTS LIST

PARTS ARE NOT TO SCALE

### LONG LADDER ASSEMBLIES (5 column corner rack only)

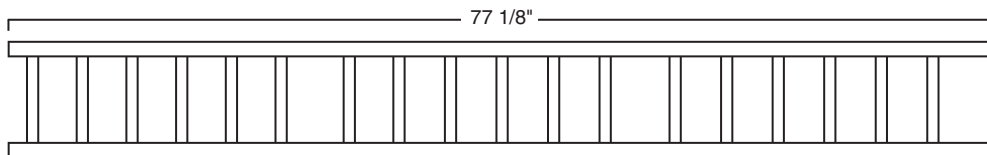

SIDE VIEW



### SHORT LADDER ASSEMBLIES

76 3/4"

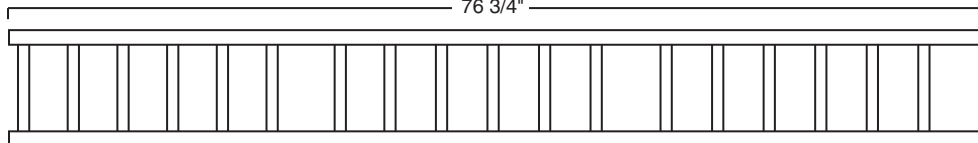

SIDE VIEW



STANDARD COLUMN CONNECTORS



SIDE VIEW



SCREWLESS COLUMN CONNECTORS



SIDE VIEW



BOTTOM CAP PIECE

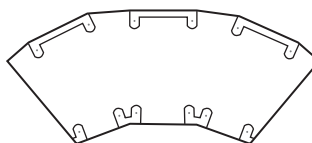

TOP CAP PIECE

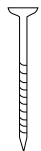
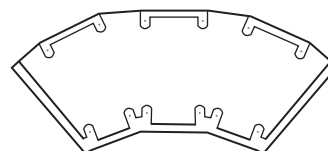

2" WOOD SCREWS



1 1/4" WOOD SCREWS



FINISH NAILS

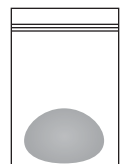

SMALL BAG OF WOOD PUTTY

# PACKAGE CONTENTS

\* Please verify that you have the correct number of parts before proceeding. Depending on the model you purchased, your bundle should contain the following:

RACK	76 3/4" LADDERS	77 1/8" LADDERS	STANDARD CONNECTORS	SCREWLESS CONNECTORS	2" SCREWS	1 1/4" SCREWS	FINISH NAILS
5 column	6	4	(30) 1 column	(10) 1 column	28	60	20
3 column	6	0	(18) 1 column	(6) 1 column	28	36	12

\* All models follow the same assembly procedure - varying only in the number of columns in your corner.

\* The 5 column and 3 column corner racks are essentially the same rack. The 3 column configuration allows you to tie into any of our modular racks on either side. The 5 column configuration comes complete with 2 - 1 column racks to complete the 90° transition and can be attached to the wall at both ends.

## \* PLEASE FOLLOW WRITTEN INSTRUCTIONS CAREFULLY

1. Find an open, flat area in which to work. Carefully remove all components from the box and remove banding with a utility knife. Check the parts list to verify package contents

*\* If you are assembling the 5-column corner, 6 of the ladders in your box measure 76 3/4" in length and 4 of them measure 77 1/8". The 6 shorter ladders make up the three main columns that will fit into the corner top & bottom cap pieces. The 4 longer ladders will be assembled as 2 standard 1-column racks and then installed under the lip on the top corner cap piece and then attached to the wall.*

2. You'll notice there is a large gap at on one end of each ladder. For each 1-column section of your rack, align two ladders so that the bottle support pieces face one another. Orient each ladder so that the large gaps are on the same end. **This is the top of your rack.**

3. Orient (3) 1-column units (using the 76 3/4" tall ladders) the same way and lay them side by side on an elevated surface like a table.

The bottom of each vertical ladder should fit snugly into the bottom corner cap piece. Attach the middle column first making sure the bottle support pieces are facing each other. Secure cap piece using the 2" screws provided. (figure 1)

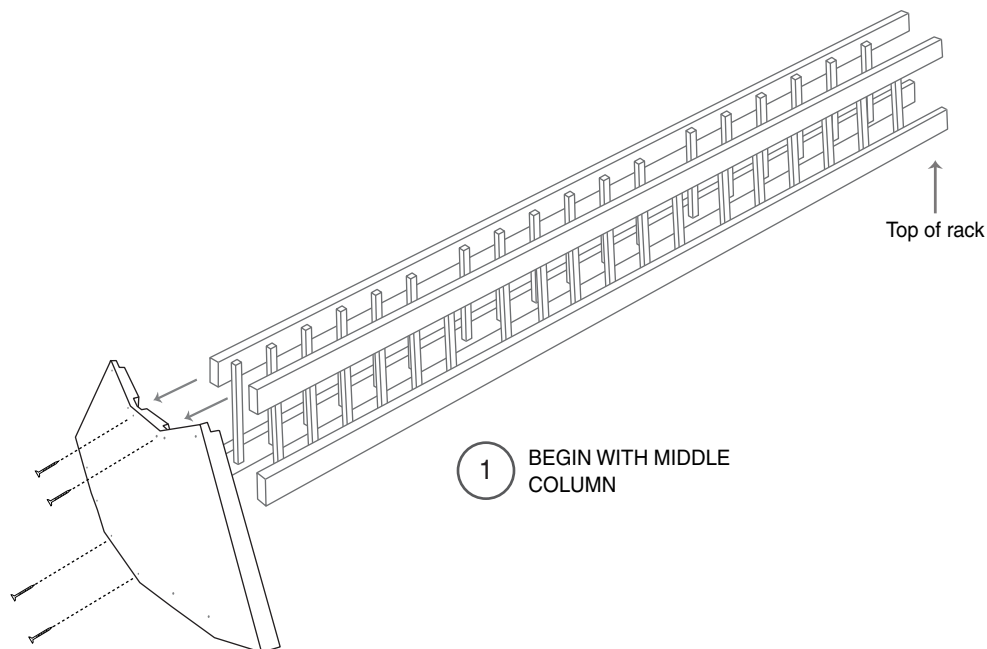

4. Once you have the middle column secured to the bottom cap piece, attach the other 2 columns. (figure 2)

\* Attach all three columns to the bottom cap BEFORE attaching the top cap piece. You may need to leave the screws slightly loose until both ends are attached, then tighten them all down at the same time.

5. Repeat the same process for the top cap piece.

6. Once the corner cap pieces are secure, lay the 3-column corner rack face down on a flat surface and begin attaching the standard 1-column connectors.

**\* Begin with the back of your rack**

First secure a 1-column standard connector to the bottom of each column so the connector is flush with the bottom of the rack. Each connector should sit snug in the groove of the bottom cap piece. (figure 3)

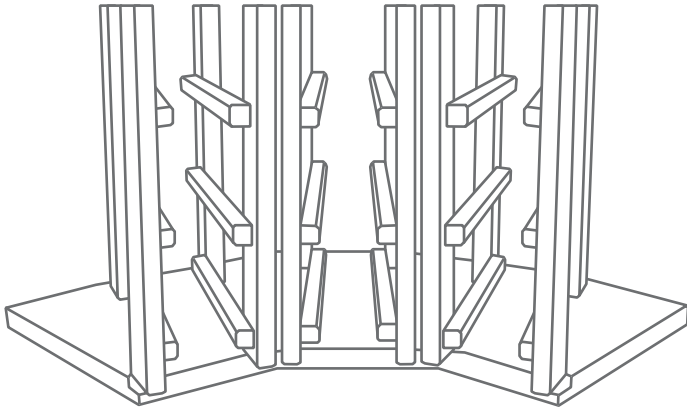

RACK BOTTOM (FRONT)

2

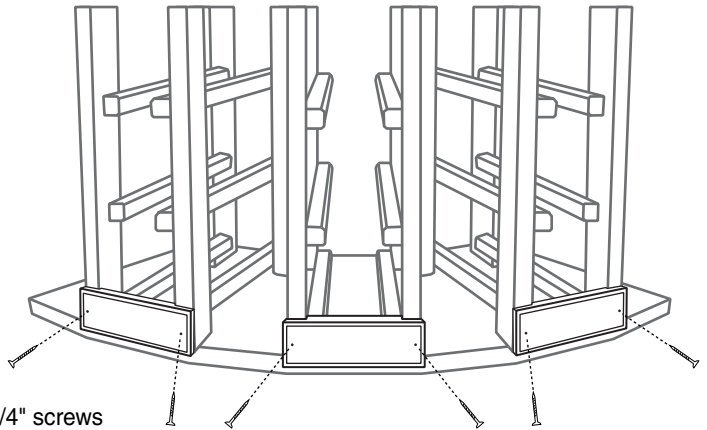

1 1/4" screws  
(provided)

RACK BOTTOM (BACK)

3

**\*Add connectors to the back of your rack first**

7. Next secure a 1-column standard connector to the top of each column so the connector is flush with the top of the vertical ladder assemblies. (figure 4)

8. Using the 1 1/4" screws provided attach the middle standard column connectors to the back of your rack. The top edge of the lower connector should be 26 11/16" from the floor, and the top edge of the upper connector should be 51 11/16" from the floor. (figure 5)

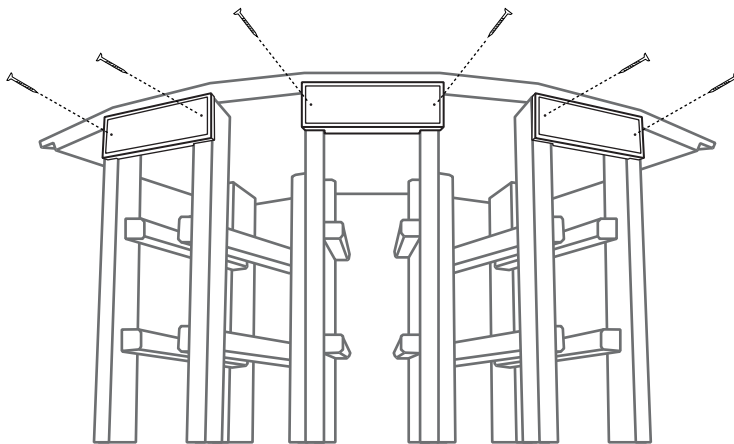

RACK TOP (BACK)

4

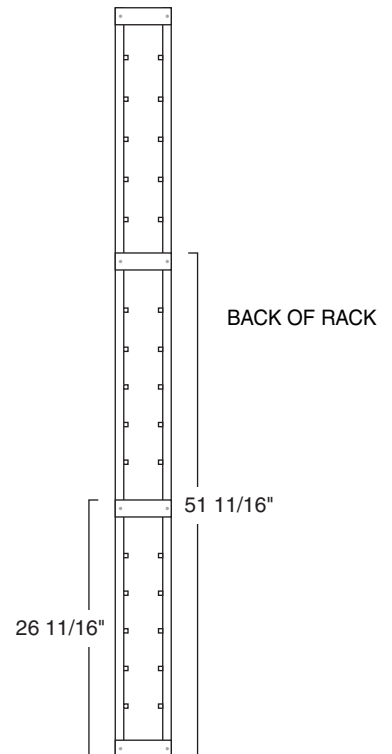

BACK OF RACK

26 11/16"

51 11/16"

5

9. Flip rack over and repeat steps 6 & 7 for securing the standard top and bottom connectors to the front of your rack.

**\*NOTE**

If you ordered the Crown & Floor molding for your corner unit, you will discard 6 of your standard 1-column connectors and attach the corner moldings in their place. The crown molding should be mounted flush with the top cap piece and the floor molding should be flush with the floor. Secure the corner molding with finish nails. (figure 6)

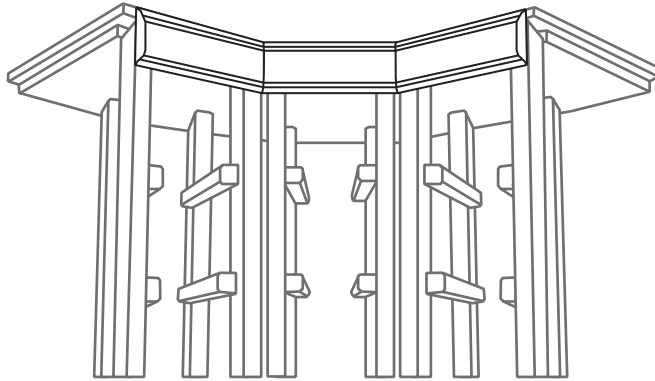

RACK FRONT (TOP)  
WITH MOLDING

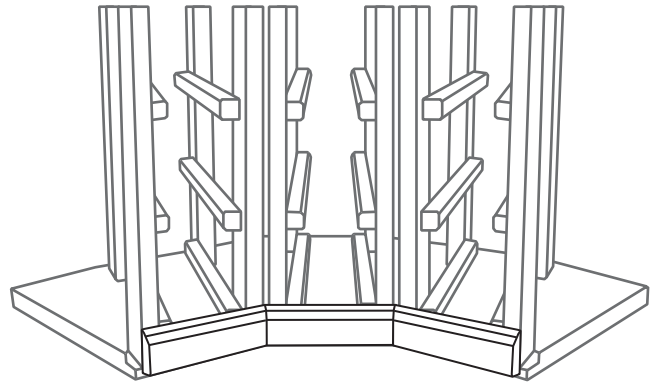

RACK FRONT (BOTTOM)  
WITH MOLDING

6

10. Locate the 1-column connectors with no pilot holes in them. Attach to the front of your rack so that the top edge of the lower connector is 26 11/16" from the floor, and the top edge of the upper connector is 51 11/16" from the floor. Make sure the rack is on a flat surface while attaching the screwless connectors. (figure 7)

Secure the screwless connectors using a finish nail gun to drive a finish nail through the connector into each vertical ladder. (figure 8)

If you do not have a finish nail gun, drive one of the provided finish nails into each vertical ladder until it is flush. Then, countersink the nail using a nail setter until the head of the nail is about 1/16" below the surface of the wood. (figure 8)

11. Fill the nail holes using the wood putty provided. Simply push the putty into each hole using your thumb and wipe excess putty off the surface using a damp cloth.

12. If you ordered the 3-column corner unit your assembly is complete. You are now ready to tie your corner unit into any of our full height modular racks.

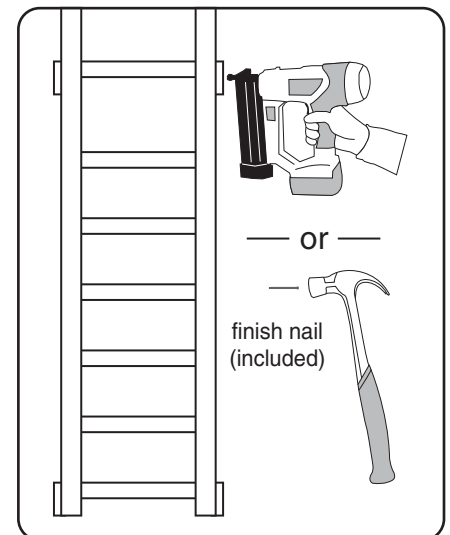
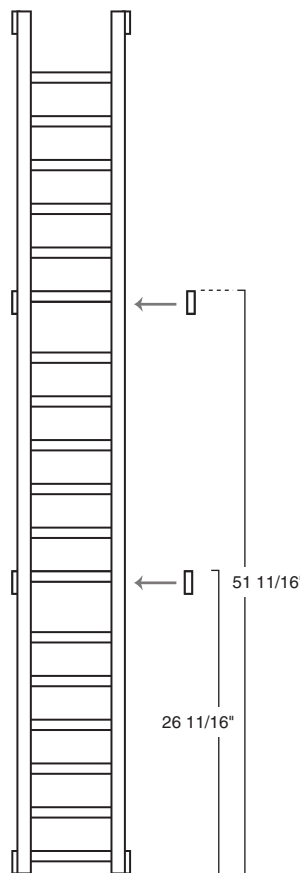

8

7 SECURING THE SCREWLESS  
CONNECTORS

**\*Proceed to the next page if you are assembling a 5-column corner unit.**

# 5-COLUMN CORNER UNIT ONLY

13. At this point you should have the components for 2 single column racks at 77 1/8" high.

Align two vertical ladder assemblies so that the bottle support pieces are facing one another. The end of the ladders with the larger gap will be the top of your rack. (figure 9)

14. Begin by securing 4 standard column connectors to one side of the rack using the 1 1/4" provided. Secure one connector flush with the bottom of the rack and one flush with the top. The top edge of the lower middle connector should be 26 11/16" from the bottom of the rack, the top edge of the upper middle should be 51 11/16" from the bottom of the rack. **This will be the back of your rack.** (figure 9)

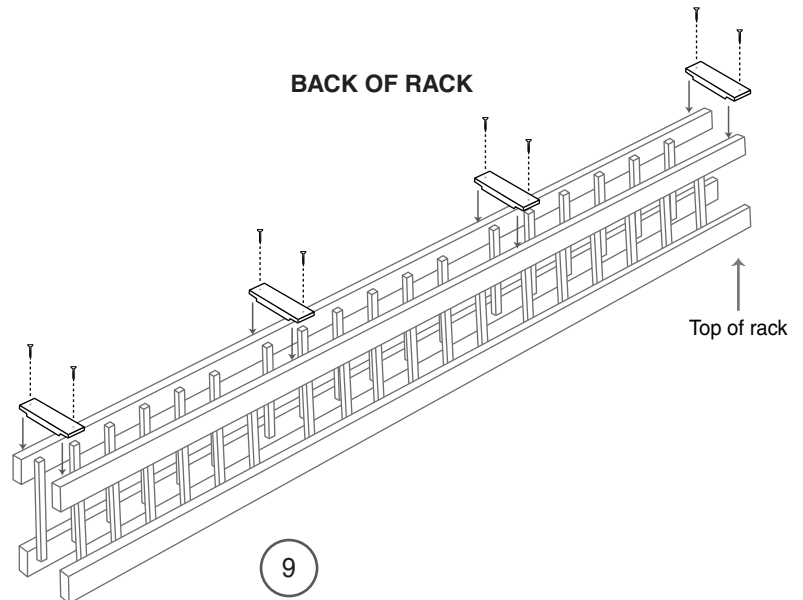

15. Flip rack over and secure a standard column connector flush with top and bottom of the front of your rack using the 1 1/4" screws provided. (figure 10)

16. Locate the 1-column connectors with no pilot holes in them. Attach to the front of your rack so that the top edge of the lower connector is 26 11/16" from the bottom of the rack, and the top edge of the upper connector is 51 11/16" from the bottom of the rack. Make sure the rack is on a flat surface while attaching the screwless connectors. (figure 10)

Secure the screwless connectors using a finish nail gun to drive a finish nail through the connector into each vertical ladder. (figure 11)

If you do not have a finish nail gun, drive one of the provided finish nails into each vertical ladder until it is flush. Then, countersink the nail using a nail setter until the head of the nail is about 1/16" below the surface of the wood.

17. Fill the nail holes using the wood putty provided. Simply push the putty into each hole using your thumb and wipe excess putty off the surface using a damp cloth.

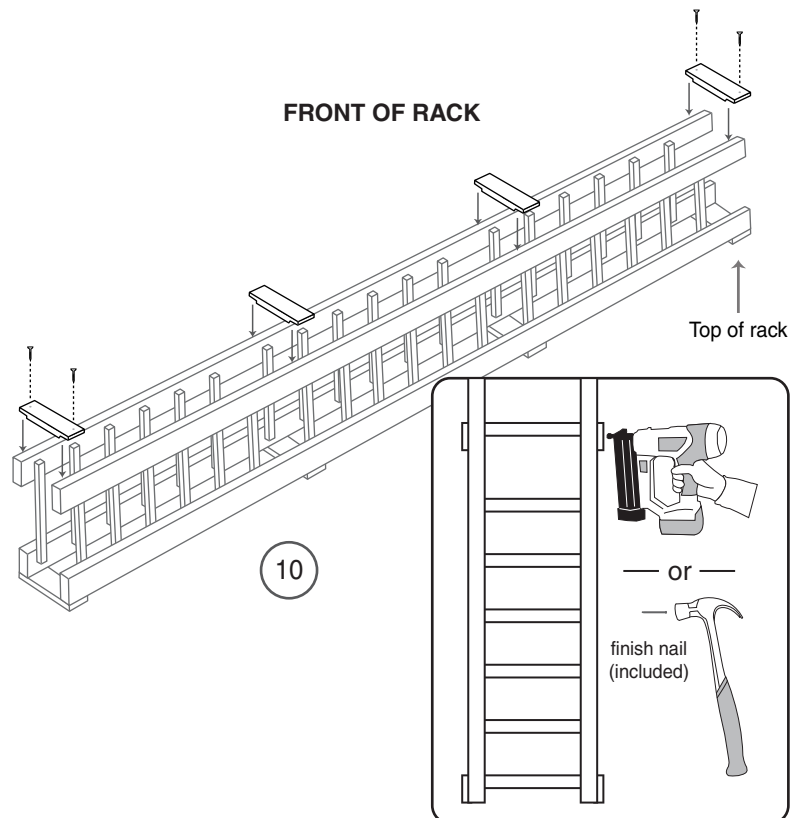

18. Repeat steps 13 - 17 to assemble the second 1-column rack. (figure 12)
19. Once you have the 2 single column racks assembled simply align each rack under the lip of the top cap piece on the corner unit. Secure the racks by driving two 2" screws down through the lip of the top cap piece into the vertical ladders of the adjacent racks. (figure 13)

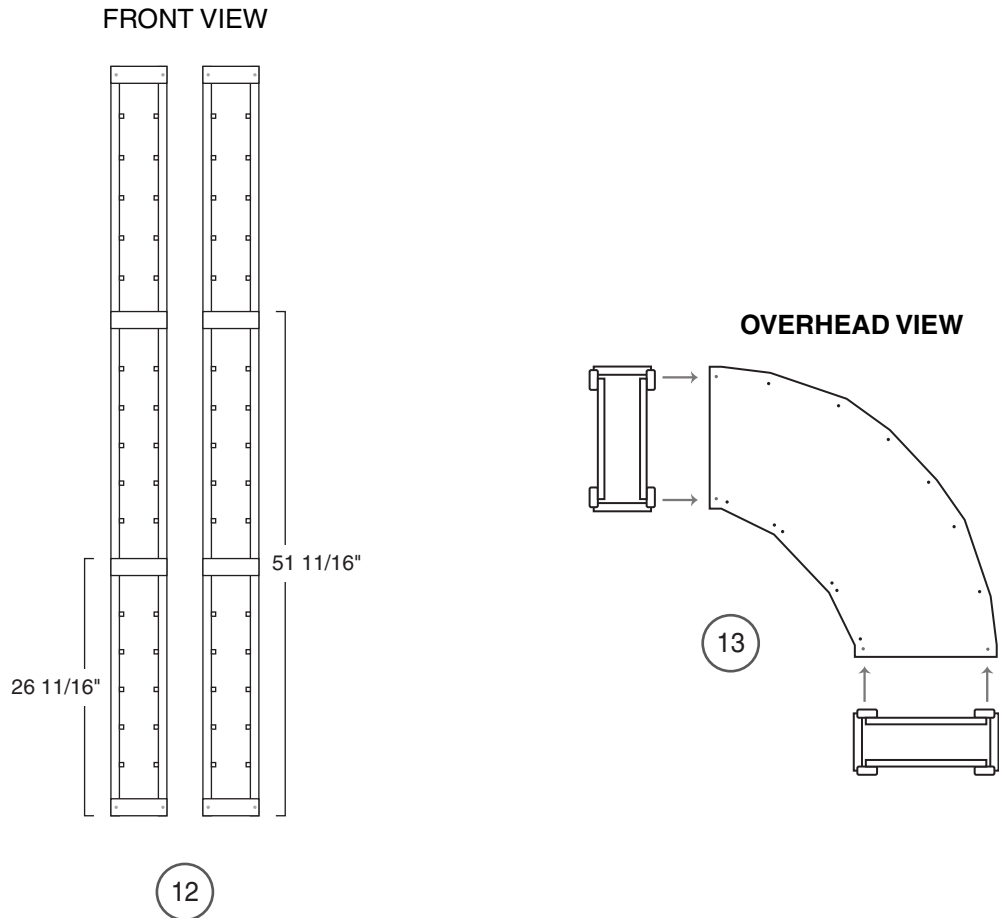

20. **Be sure your wall racks are attached to the wall**  
Depending on how many bottles you store, your wine cellar rack could weigh as much as 280 lbs. To avoid tipping, anchor whatever wall rack that your corner unit is attached to by securing it to studs in the wall.
21. That's it! Enjoy this beautiful rack with your favorite beverage. Pair with other rack styles for an ultimate cellar storage look.



**WINE RACKS AMERICA**

360 N 700 W suite F • North Salt Lake, UT 84054  
(toll free) 888-373-6057  
(fax) 801-936-0534

WineRacksAmerica.com

Once again thank you for your business. Remember, customer service is available to answer your questions M-F 7:00 am - 5:00 pm MST. Please feel free to contact us for any wine storage need.