



WINE GUARDIANTM
Wine Cellar Cooling Systems

Humidifier
Installation, Operation and Maintenance Guide

Manufactured by:

Wine Guardian division of Air Innovations, Inc. Syracuse, NY

www.wineguardian.com

www.airinnovations.com

Wine Guardian reserves the right, without notice, to make changes to this document at our sole discretion.

Please visit our web site for the most current version of the Wine Guardian Manual and other literature.

Wine Guardian is a registered Trademark (76/551,126) of Air Innovations, Inc.

Edition 8/2005

INTRODUCTION

Dear Customer,

Congratulations and thank you for purchasing a Wine Guardian Humidifier. We believe it to be the best wine cellar humidifier on the market and hope you will find the same.

This guide is intended to help the installer and owner of the Wine Guardian humidifier to properly install and maintain the equipment. In order to ensure long and trouble free life, the equipment should be installed properly and have proper care and maintenance. Please read this guide carefully, especially the safety instructions, and keep it for future reference.

Receiving, Unpacking and Inspection

Wine Guardian humidifiers are shipped in an individual cardboard box. Each humidifier and humidistat is factory assembled and tested prior to shipment.

Upon receipt and before opening the container, inspect the packing crates or boxes for obvious signs of damage or mishandling. Write any discrepancy or visual damage on the bill of lading before signing.

Find the packing slip and check for completeness of contents. Make sure it is the correct model you ordered including factory options and accessories.

Your Wine Guardian humidifier has a humidistat wired into the terminal strip on the unit and a drain line coming out of the unit. Inspect all equipment for any sign of damage or loose parts caused during transit. Immediately report all visual or concealed damage to the carrier and file a claim.

Note: If this procedure is not followed, the shipping company may reject the claim and the consignee may suffer the loss. Do not return the shipment to the factory.

Directory of Terms

Ambient – the area outside the cellar. Could be another room, a basement, garage or outside.

BTU/H – British Thermal Unit per Hour is a unit of heat measurement. For example, one ton of cooling equals 12,000 BTU/H.

Cellar – the wine storage area being conditioned by the Wine Guardian unit.

CFM – cubic feet per minute. Unit of measurement for the amount of air being handled by fan.

Condensate / Condensation – the water formed out of the air when it is cooled below a certain temperature (called dew point). Often referred to as “sweating” on pipes and cold surfaces. This water is collected at the bottom of the evaporator or cooling coil and drains out of the unit thru the drain line.

Evaporative pad – the wire mesh pad inside the humidifier which becomes coated with water as the water drips down by gravity. Air being drawn over the pad by a fan causes the water to evaporate into the air, increasing it's moisture content.

Grille or Diffuser – inlet or outlet plates to direct the airflow or protect the inside of the unit.

Humidistat – an electronic instrument which measures the relative humidity of air and reads in percentage (%).

Humidity – Relative Humidity is the percentage of moisture in the air relative to the maximum amount of moisture the air could hold at any particular condition. Relative humidity is what is most widely used and is what a humidistat measures. For example, 100% relative humidity means the air has as much moisture as it can possibly hold at that temperature. Absolute or specific humidity is the specific amount of moisture (usually measured in grains of moisture per pound of air) in the air at a given air condition.

Heat Gain / Loss – the amount of cooling or heating expressed in BTU/H that is gained or lost into or out of the wine cellar to the ambient space. It is this load which the Wine Guardian must be able to offset.

Moisture – water which has been evaporated into the air

Recovery – the amount of cooling or humidifying the unit must do to return the cellar to its' set point temperature or humidity after some new load has been introduced, such as people in the cellar or new cases of warm wine coming in.

Return / Inlet Air – the air returning from the cellar and entering the evaporator section of the Wine Guardian unit. Also the air entering the condenser section.

Set point – the desired temperature or humidity that is set on the Thermostat or Humidistat.

SP – static pressure. Unit of measurement (in inches of water column) of the pressure of the air being handled by the fan.

Supply / Discharge Air – the air leaving the Wine Guardian unit and going into the cellar from the evaporator section. Also the air leaving the condenser section.

General Description

The Wine Guardian humidifier is a professional, USA manufactured, self-contained unit designed specifically for wine cellars. It has been designed for easy installation and operation, either as a free-standing unit or mounted on a Wine Guardian cooling unit. Wine Guardian uses a humidistat to sense and control the amount of moisture needed to be added to the cellar. Humidifiers are not intended to remove moisture, only add moisture. All components are of a high quality, standard commercial grade. The humidifier operates with 24volt power only and therefore does not require UL or CSA approval. All wiring shall comply with NEC. The free standing humidifier also comes with a sealed plug in transformer and lead cord to allow the unit to operate independent of a Wine Guardian cooling unit.

Wine Guardian humidifiers are the evaporative drip pad type. Air from the cellar is drawn over a distribution pad which is saturated with water from a distribution tray. As the air passes thru the pad, it absorbs moisture thru evaporation of the water. This raises the humidity of the leaving air which returns to the cellar. Hot water is recommended as it increases the capacity of the humidifier to evaporate the water as it passes thru the pad. The hot water also leaves less solids on the surfaces of the pad and flushes contaminants out of the pad. Excess water is collected in the bottom trough and exits through the drain.

To avoid build-up of mineral deposits on the pad and potentially causing blockage of the air flow, it is recommended that hard water be treated (filtered and softened). Install a 5 or 10 micron in-line water filter ahead of the humidifier to keep dirt from fouling the inlet screen and the evaporation pad inside. If the water has a high mineral content, a softener may be needed to prevent excessive scale from building up too rapidly on the pad.

Additionally, to insure adequate wetted surfaces and to help flush away excess minerals, the water flow is set to always have a flow of water to the drain. When operating, the humidifier will use approximately 1 to 2 gallons of water per hour depending on the water pressure in the building. About 60% of that will pass thru and go out the drain. There is a strainer and an orifice in the line to restrict the flow of water but a throttling valve may be needed to keep too much water from going to the pad. All that is needed is a steady dripping of water out of the drain to ensure adequate wetting and flushing of the pad media. Excess water doesn't hurt but it also doesn't do any more humidifying. The drain volume is too much for just a bucket. A gravity drain line should be piped to an open floor or sink drain, or a condensate pump may be used where a gravity drain is impractical. This excess drain water can be discharged directly onto the ground. The discharge of the drain can be combined into the condensate drain from the cooling unit.

The humidistat, located in the cellar, will automatically turn on the humidifier whenever the cellar humidity is below the setpoint and turns it off when the cellar humidity reaches setpoint. The recommended setpoint is 50% for wine cellars. This humidity level is high enough to prevent corks from drying out and low enough to prevent mold from forming. When the unit turns on, the water solenoid valve opens and the fan turns on. When mounted and connected to a wine guardian cooling unit, the humidistat also controls the main fan to circulate air to and from the cellar.



CAUTION

CAREFULLY FOLLOW THE INSTALLATIONS INSTRUCTIONS INCLUDED WITH THE HUMIDIFIER. REFER TO THE MANUFACTURERS INSTRUCTIONS CONTAINED IN THE BOX FOR THE HUMIDISTAT. WE RECOMMEND YOU KEEP THESE INSTRUCTIONS IN A FOLDER ALONG WITH THIS GUIDE FOR FUTURE REFERENCE.

Size and Capacity

The Wine Guardian humidifier uses a 10" wide x 11" high x 2" thick expanded coated aluminum pad. It's rated output capacity for wine cellars at 55°F is 1.6 gallons per day (gpd) with 60°F water supply, 3.3 gpd with 90°F water and 5.1 gpd with 120°F water. The weight of an operating humidifier is approximately 10 lbs.

OVERVIEW – *refer to call outs on drawing*

Adapter plates – metal plates used to mount the humidifier to the different sizes of Wine Guardian cooling units.

Cabinet – The cabinet and access doors are constructed of 0.063" gauge aluminum with a powder coated finish. This affords corrosion protection and an attractive, maintenance free appearance. Areas in contact with cold temperatures are lined with a dense, closed cell insulation to prevent condensation.

Distribution Tray – the plastic water trough into which the water drips and is distributed evenly over the drip pad thru several holes evenly spaced in the trough.

Drain – collects excess water at the bottom of the pad and is piped to an external drain.

Electrical Controls – Most of the electrical components and controls are located in a separate box on top of the humidifier. All wiring is done in accordance with the National Electrical Code. Wires are numbered and color coded to match the wiring diagrams.

Evaporative Drip Pad – the expanded metal pad thru which the cellar air flows and the water drips down the surfaces.

Factory tested – all Wine Guardian humidifiers are factory run tested and checked for operational performance.

Fan – turns on and off on signal from the humidistat on a call for humidity in the cellar. The fan draws air across the evaporative drip pad to absorb moisture.

Grille – for free standing applications only. Used to separate the inlet air from the discharge air.

Orifice – small fitting with a very small hole in the center to restrict the flow of water

Strainer – conical shaped stainless steel screen in a plastic frame to capture any sediment in the water and keep it from plugging the orifice.

Water Solenoid Valve – opens and closes to control the flow of water into the distribution trough on signal from the humidistat.

Dimensional Drawing

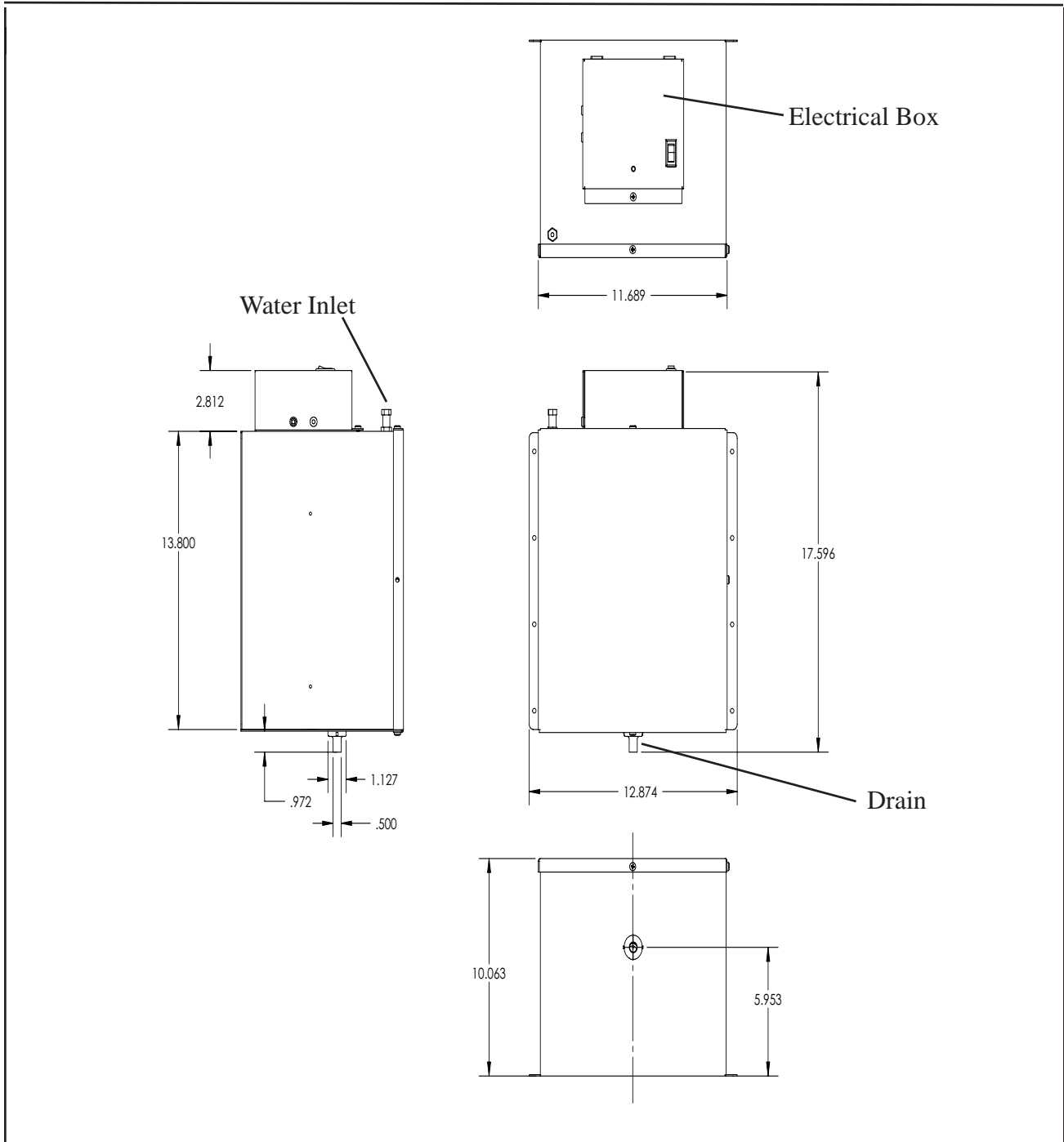

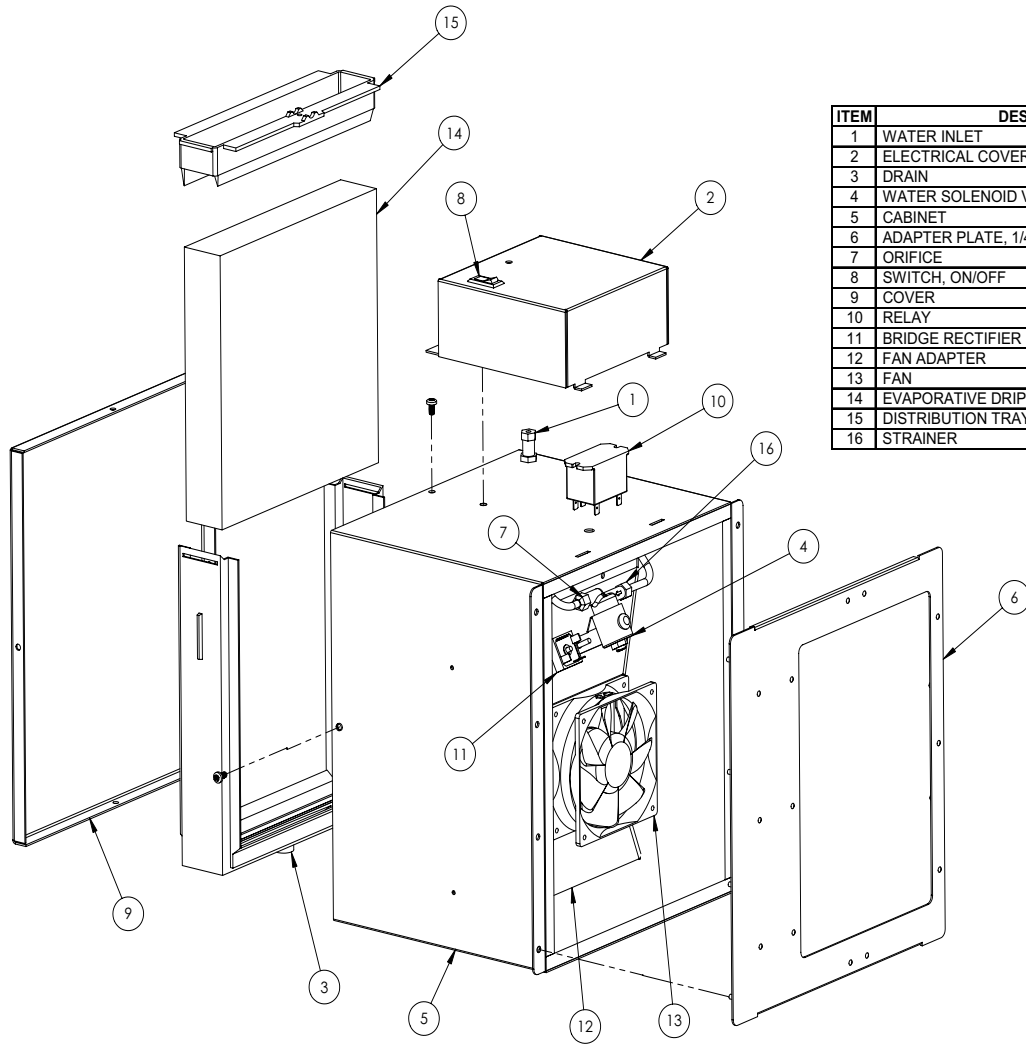

ITEM	DESCRIPTION
1	WATER INLET
2	ELECTRICAL COVER
3	DRAIN
4	WATER SOLENOID VALVE
5	CABINET
6	ADAPTER PLATE, 1/4, 1/2 & 1 TON OR 2 TON
7	ORIFICE
8	SWITCH, ON/OFF
9	COVER
10	RELAY
11	BRIDGE RECTIFIER
12	FAN ADAPTER
13	FAN
14	EVAPORATIVE DRIP PAD
15	DISTRIBUTION TRAY
16	STRAINER

WIRING DIAGRAM
WINE GUARDIAN HUMIDIFIER

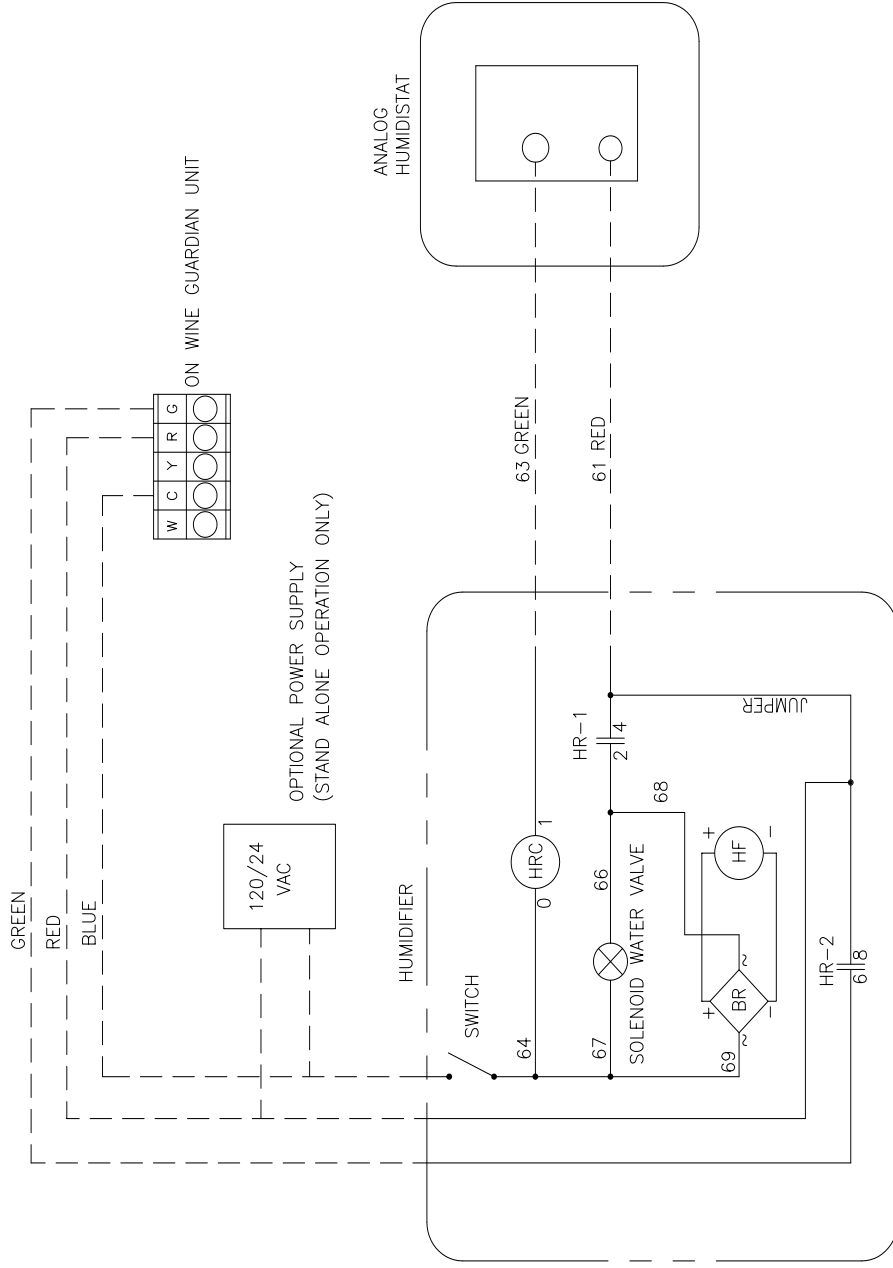

KEY

-  HUMIDIFIER RELAY COIL
-  24VDC HUMIDIFIER FAN
-  BRIDGE RECTIFIER

SAFETY

The Wine Guardian humidifier uses only 24volt power. However, that power comes from a transformer which uses 120volt power. Therefore, before servicing the humidifier, be sure to disconnect the main power to the cooling unit or to the humidifier.

The water supply to the humidifier may be hot. Turn off the humidifier and allow the water to cool before servicing the humidifier.



Metal edges can be sharp and cause injury if not handled properly. Fan blades can also be sharp. Do not put fingers or other objects into a moving fan.

INSTALLATION



Humidifier may not be installed where it might be exposed to freezing temperatures. If the cooling unit is mounted outside, the humidifier will have to be mounted in the supply duct to the cellar inside the building or mount the humidifier as free standing inside the cellar.

Pre-installation check

To check for any possible non-visible shipping damage, you may wish to test the unit before actually installing it. To do so, remove the unit from its packaging and set it on any sturdy level surface. If a freestanding unit, plug in the unit. If the unit is to be mounted into a cooling unit, you need to wire the humidifier to the cooling unit and the cooling unit must be turned on. Then turn on the rocker switch on top of the humidifier. The switch light should come on. This indicates the unit has power. Set the humidistat above the room humidity. The unit should now come on. The water solenoid should open and the fan should come on. Listen for any unusual noise or vibration. Turn the humidistat below the room condition and the unit should go off.



- **Never modify this equipment. Changes or modifications may void the warranty, cause damage to the equipment, and/or create a safety hazard.**
- **Never place anything on top of the unit. Never block or cover any of the openings or outlets of the unit.**
- **Never allow anything to rest on or roll over the power cord, and never place the unit where the power cord is subject to wear or abuse.**
- **Do not remove or open any access door or cover unless the unit is unplugged.**

Free Standing Installation

Mount the unit on a flat surface over a hole for the drain or mount on a wall. Make sure the unit is level and plumb in all directions. Mount the face grille on the unit. If thru-the-wall installation, an insulated sleeve must be used.

Install a ¼” hot water line from the water supply into the opening on the top of the humidifier. Use flexible tubing to allow the unit to be rotated. A shut off valve (not provided) is recommended to isolate the humidifier from the water system when needed.

Install a ½” flexible drain line from the bottom of the humidifier to an open drain or connect into the drain line from the cooling unit.

Connect the wires from the power cord to the terminal strip on the unit. Plug the power cord into a 120v standard outlet. Install the outlet grille on the humidifier being careful to properly position the divider plate.

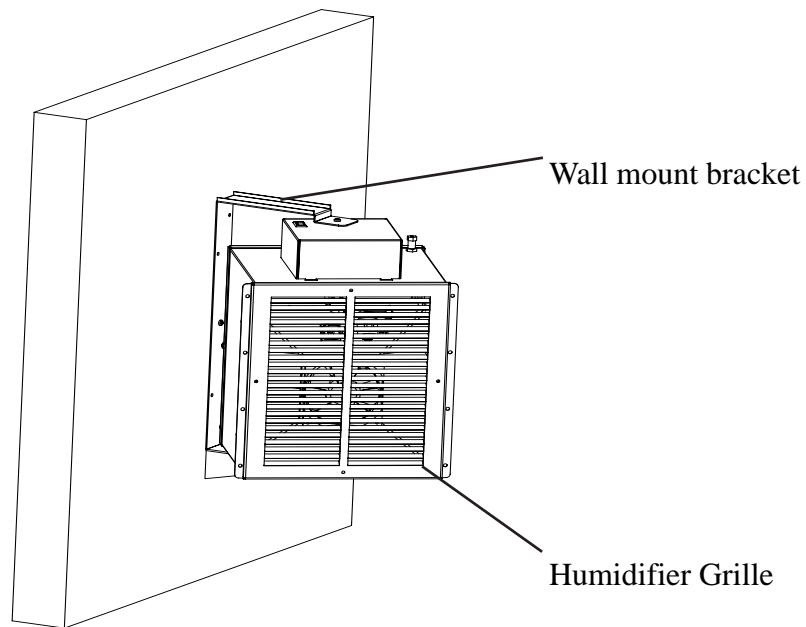

Wine Guardian mounted installation

Remove side access panel on the side of the cooling unit where you wish to mount the humidifier. NOTE: Humidifiers are to be mounted in either of the two side openings of the cooling unit on the cooling or evaporator end only. Do not mount the humidifier on the condenser end of the unit. If a duct connection is in that position, move the duct connection to the top or other side. Select the proper adapter plate for the cooling unit and install in the side opening using the screws from the panel removed above. Mount the humidifier to the mounting plate, making sure the unit is level and plumb. Care must be taken to be sure the gaskets on both the adapter plate and humidifier are fully engaged to prevent air leakage.

The adapter plate allows the humidifier to be mounted in either a forward position or back toward the center by simply rotating the adapter plate 180 degrees.

Install a ½” flexible drain line from the bottom of the humidifier to an open drain or connect into the drain line from the cooling unit.

Install a ¼” hot water line from the water supply into the opening on the top of the humidifier. A shut off valve (not provided) is recommended to isolate the humidifier from the water system when needed.

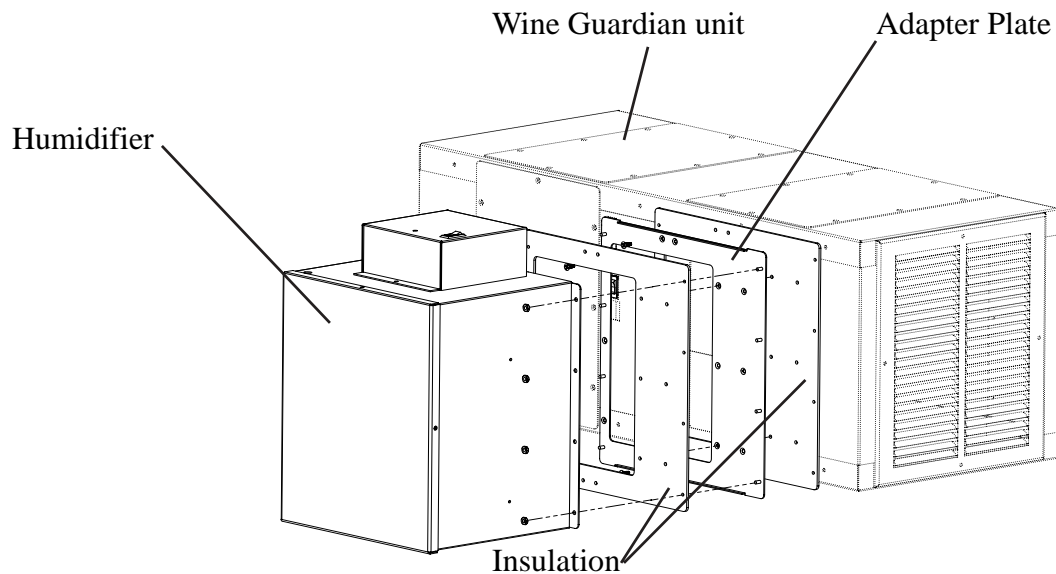

Mounting the Humidistat

Each Wine Guardian humidifier comes with a humidistat and 25’ of wiring. It is factory wired and has been tested at the factory. If you need to remove the wires from one or both ends to install the wiring, please note the color-coding and replace the wires in the correct location. After the wires are re-installed, test with a slight pulling motion back on the wire. If additional wiring is needed, it can be spliced onto the factory-furnished wire being sure to match colors for continuity and to insulate each wire separately with electrical tape.



Be sure that each colored wire is in its proper color-coded slot on the terminal strip and that they are tight. Miss-connected humidistat wiring may result in improper operation and/or cause damage to the unit and humidistat.

Mount the humidistat on a solid surface away from doors, corners, air outlets or other drafty or heat generating equipment. Do not mount directly on an outside wall or wall adjacent to a boiler room. Use a piece of foam insulation behind the humidistat to insulate it from the hot or cold surface. The recommended height is 4’ to 5’ above the floor. The humidistat is often located next to the thermostat.

For the unit mounted humidifier, wire the humidifier to the terminal strip on the Wine Guardian cooling unit using the wire provided. Be sure to match the wire color with the color code on the terminal strip.

START-UP AND OPERATION

Now that the installation is complete, it's time to start the unit. Check to make sure all connections are secure. Turn on the cooling unit if so mounted. Turn-on the rocker switch on the top of the humidifier. Test the operation by setting the humidistat above the room condition. The humidifier should come on, the water solenoid should open and water should flow. It may take a few minutes for water to appear in the drain line. Set the humidistat below the room condition and the humidifier should shut off. Follow the manufacturers' directions with the humidistat for calibration and trouble shooting.

Humidistat



The humidistat is used in a broad range of applications and the manufacturers' literature contains information that may not be specific to your wine cellar application. Refer to the manufacturers instructions contained in the box with the humidistat. We recommend you keep these instructions in a folder along with this guide for future reference.

Refer to pages 3 & 4 – disregard the wiring diagrams shown here. Refer to the wiring diagram shown in this guide.

Set the humidistat at the desired humidity, recommended between 40% and 60%, which is adequate to prevent drying out of corks and not so high as to risk mold growth. Over humidifying can cause mold growth and sweating on surfaces and loosening of labels on bottles.

Note that the humidifier can only add moisture, not remove it. Removal, or dehumidification, is a function of the cooling system as it lowers the temperature of the air below its' dew point at which moisture condenses out onto the cooling coil and into the condensate drain. Therefore, the humidistat will only control the addition of moisture.

The amount of humidification and dehumidification is mostly dependent on the relative humidity of the ambient air and on the quality of the insulation and vapor barrier in the cellar. In southern climates, humidification is not normally the dominant need, just cooling and dehumidification. In northern, colder climates, winter weather will result in low humidity levels indoors. This requires more need for humidification to keep the moisture level in the cellar up above 40%, especially in higher elevations where the air is dryer.

inspection and Start-up checklist

Handling and Installation

- Unit mounted on solid level surface
- Sufficient space allowed for access to unit and accessories
- Proper electrical service provided
- Hot water provided to humidifier
- Drain line is installed with proper pitch
- Ductwork, fittings and grilles installed properly
- All cold duct surfaces insulated
- No obstructions to air flow

Unit startup

- General visual inspection
- All wiring connections checked
- All ducts, grilles and panels in place
- Start unit
- Check connections for air leaks and water leaks
- Check for excessive noise or vibration
- Check for operation of humidifier

Maintenance

General



Before performing maintenance on the unit, read and understand the safety information contained in this guide.

The Wine Guardian is designed for minimum maintenance. Never oil any part of the humidifier. Always disconnect the electrical power to the humidifier and the cooling unit if used.

A regular maintenance program prolongs the life of the humidifier and maintains the humidity in the cellar. Frequency of cleaning and replacement of the drip pad depends on the inlet water conditions and the cleanliness of the cellar air. The drain system may also trap dust and dirt. When water no longer stays on the pad or mineral build-up has started to reduce airflow, the pad needs to be replaced.

Suggested maintenance schedule:

- Monthly – may change to quarterly depending on experience with individual cellar
 - Check drain – clean if needed – confirm steady flow of water while in operation
 - Check for noise or vibration

Yearly – in addition to above

Clean the humidifier and replace humidifier pad if needed (see procedures below)

Inspect cabinet for corrosion or rusting – clean and paint

Check for any loose insulation, fasteners, gaskets or connections

Check wiring connections and integrity of cords

Check operation of humidifier fan and water solenoid

Cleaning the Humidifier and Replacement of Evaporative Drip Pad

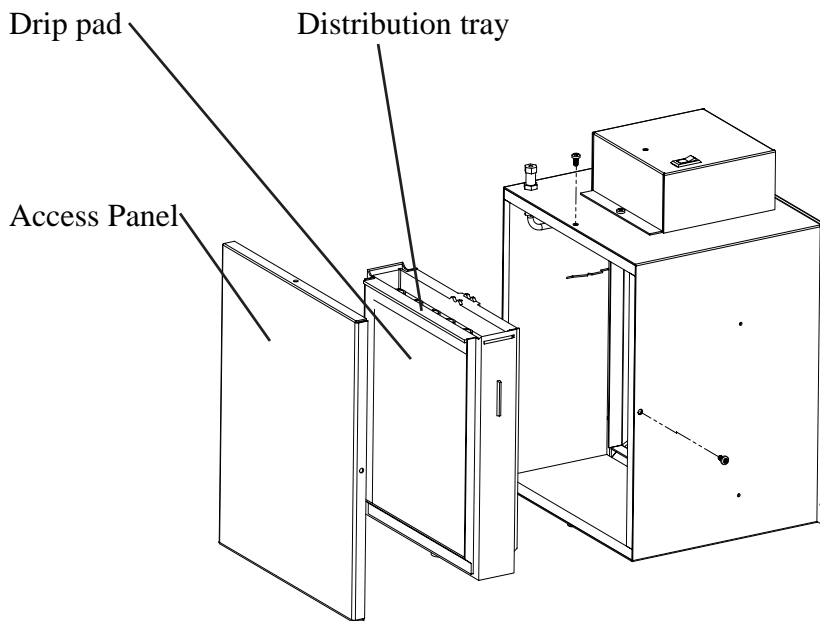

Before starting work, be sure the power to the Wine Guardian cooling unit and humidifier are turned off. Make sure the power cord is disconnected from the power source.

1. Start by disconnecting electrical power and shutting off the water supply
2. Remove the access panel at the back of the humidifier.
3. Remove the drip pad and its plastic holder from the unit as an assembly by grasping the top of the holder and pulling toward you, top first. Be sure the water feed tube is clear of the top distribution tray.
4. Pull one side of the humidifier pad assembly frame toward you and remove the distribution tray from the frame
5. Slide the humidifier evaporator pad out of its frame. Clean the frame by twisting and flexing it to loosen any calcium deposits, or use a putty knife.
6. Carefully scrape any mineral deposits from the tray and frame. Be sure the frame drain hole has nothing blocking it. Remove any calcium deposits from the “V” notches in the distribution tray but **do not** scrape off the granular coating from the bottom. This textured surface helps ensure even water flow for maximum performance.
7. To clean the drain, pour some hot water mixed with a cleaning solution into the pan to flush the dirt down the drain tube.

8. Check the humidifier pad and if dirty or excessive mineral deposits are present, install a new evaporative pad. Replace the pad by sliding the pad back into the frame. **Note:** the pad must be installed in the correct position. There is a black spot painted on one end of the pad. This is the top of the pad and must be installed with the **colored spot UP**, next to the distribution trough. There is no inlet or outlet side for the airflow, only the requirement that the black spot be on the top.
9. Reattach the distribution tray to the frame by snapping into place.
10. Reinstall the entire pad, frame and tray assembly, making sure the drain fits into the drain fitting at the bottom and that the entire unit snaps into place and is held securely.
11. Be sure the water feed tube is aiming into the center of the tray
12. Turn on the water and power.
13. Check for operation. See instructions under startup. Be sure water is flowing into the distribution tray and flows freely out the holes and over the pad. If water flow is not a steady flow, the strainer and/or orifice may need service. See below.
14. Replace the humidifier access cover.

Humidifier Water Line Maintenance (See detail)

1. Repeat steps 1 & 2 above
2. Disconnect the water line at the inlet to the solenoid valve.
3. Remove the in-line strainer from inside the inlet fitting by using the small loop of a paperclip or wire with a loop on the end to catch the plastic lip when pulling out. Do not insert anything with a sharp end on it as it might penetrate the strainer and render it useless.
4. Clean the strainer by flushing under hot water or immersing in a demineralizing solution to break down the mineral deposits. Inspect and replace the strainer if it cannot be cleaned or if the screen is damaged.
5. Reinstall the strainer in the valve inlet and replace the tubing and tighten the compression nut. Double wrench to prevent damage and leaks.
6. Disconnect the water line on the outlet of the solenoid valve.
7. Remove the orifice from the copper tube and make sure this small opening is unplugged.
8. Replace the orifice and reconnect the outlet water line. Double wrench to prevent leaking.
9. Reinstall the in-line strainer and reconnect the inlet water line. Double wrench to prevent leaking.
10. Turn on water supply and reconnect electrical power to the humidifier.

Water Line Maintenance Detail

